

**Installation Instructions**  
**Sunnex HM Exam Light**  
**Models: HM1006-37W, HM28002W, HM1000-37W, HM2017-44**

**1.1 Applications**

This HM LIGHT is intended to be used as a medical examination lamp in consulting rooms and health care centers.

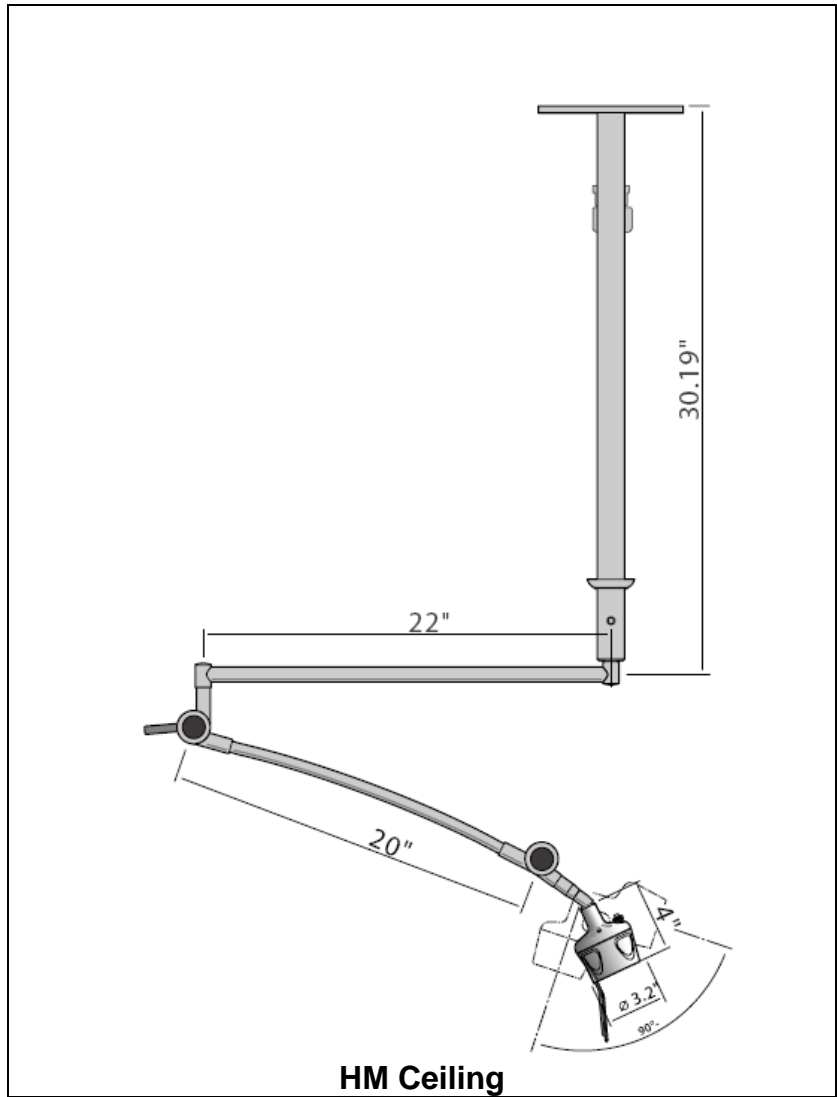

## 1.2 Cleaning and Disinfection

The lamp fixture can be cleaned as needed with a damp cloth and a mild detergent. For disinfection use a soft cloth with a disinfectant solution such as isopropyl alcohol. NOTE! Do not introduce any fluids to the inside of the lamp head as this could cause a fire hazard.

The glass lens can be cleaned with a damp cloth and a mild detergent and inside part of the lens can be easily cleaned with Q-tips.

## Technical Data

### 2.1 Manufacturer

Sales office	Production Facility
Sunnex, Inc. 3 Huron Drive Natick, MA 01760, USA Phone: 508-651-0009 Fax: 508-651-0099 Email: sunnex@sunnex.com	Sunnex, Inc. 3 Huron Drive Natick, MA 01760, USA Phone: 508-651-0009 Fax: 508-651-0099 Email: sunnex@sunnex.com

### 2.2 Technical Data

Main Voltage	120VAC 60Hz (230V 50Hz available)
Nominal effect	60W
Safety Class	I
Transformer	Medical Grade Plug-in transformer INPUT: 120VAC, 60Hz, 0.5A, OUTPUT: +12VAC, 5.0A MAX. Part# GS-1451  INPUT: 230VAC, 50Hz, OUTPUT: +11.5VAC Part# 18395 (EURO), 18396 (UK), 18397 (AUSTRALIA)
Bulb	12V/20W/NSP
Color Temperature (CCT)	3584 Kelvin (at 1meter)
Color rendition index (CRI)	95 (at 1meter)
Total irradiance	16 W/m <sup>2</sup> (at 1meter)
Certifications	<b>ETL Listed:</b> CAN/CSA-C22.2 No. 601.1-M90 EN60601-1, UL60601-1, EN60601-2-41 IEC60601-2-41, IEC 60601-1-2 (2001-09) 2nd edition (EN55011:1991, Group I Class B)

Only original accessories must be used with HM light. The HM light is equipped with a push-button ON-OFF switch on the lamp head that should be used to turn the light ON and OFF.

### EMC

The lamp complies with the EMC requirements in accordance with EN 60601-1-2. Wireless transmission equipment e.g. mobile phones etc. should not be used in the vicinity of the lamp since this can affect the function. Special care should be observed during the use of strong sources of interference e.g. diathermy and the like, so that the diathermy cables not are placed on or close to the lamp. If in doubt consult your technician or the supplier. Accessories other than here mentioned are not allowed to use as they may negatively affect emissions and immunity. The complete light must be recycled in accordance with WEEE standard.

### 2.3 Transportation and Storage

This light is packaged in card board and should be transported protected from moisture. The light should be stored in a dry environment and room temperature.

Transportation and storage temperature: -5°F / -20°C to 140°F / 60°C

Humidity < 95%

### 2.4 Bulb replacement

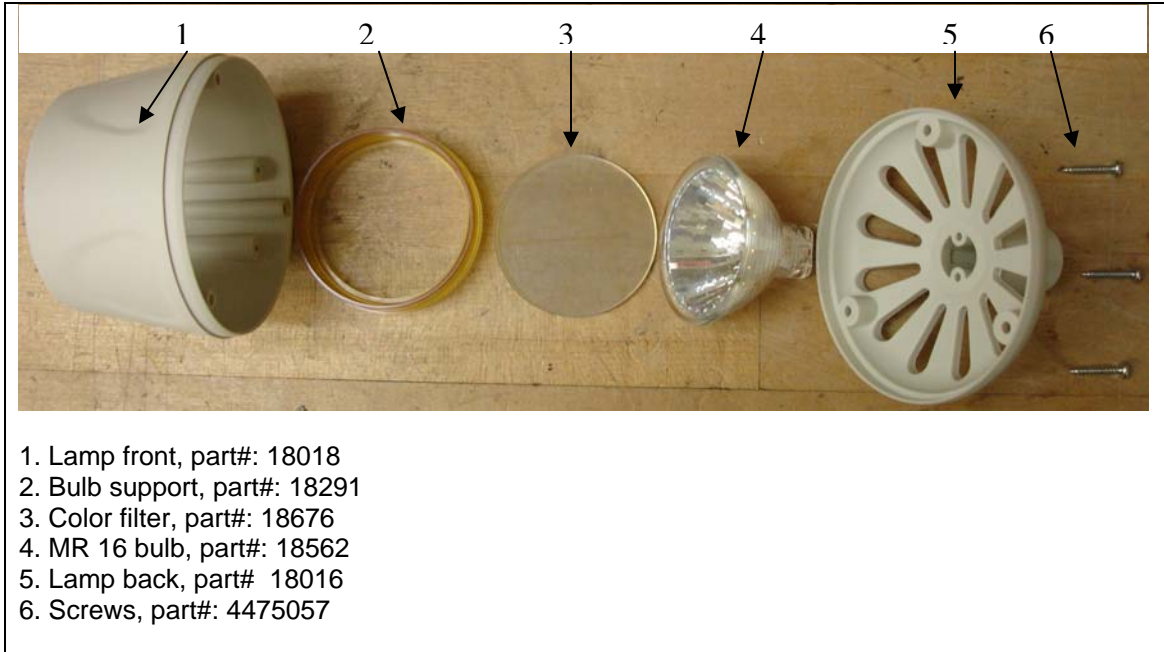

1. Unplug lamp from power source and wait at least one hour for lamp to cool.
2. Loosen the connecting cable from the transformer to make sure that lamp is not supplied with voltage.
3. Unscrew the three screws from back cover of the lamp.
4. Remove the halogen cold light bulb from its socket.
5. Replace the damaged halogen cold light reflector. Only Sunnex cold light reflector with part. no. 18562 must be used. **NOTE!** Make sure the cold light reflector is clean and without fingerprints.
6. Refit the back cover, with the three screws. **NOTE!** The color filter must not be removed, since the color temperature of the lamp depends on this. A damaged color filter must be replaced immediately.

**CAUTION! Be sure the lampshade components are properly seated when screws are tightened!**

### 2.0 Assembly Instructions

### 2.1 HM LIGHT Mobile (HM1006-37W)

1. Place the pole (2) in the center housing (4)
2. Press down until you feel resistance.  
Assemble the clamp plate (5) using the provided screw (7) and washer (6). Do not tighten the screw. The teeth on the plate should face inwards.
3. Insert each of the 5 legs into the center housing, and place the 2 lockable casters on opposite sides.
4. Tighten the screw (7). Secure the legs in the housing by lining up the teeth on the clamp plate (5) with the holes in the legs.

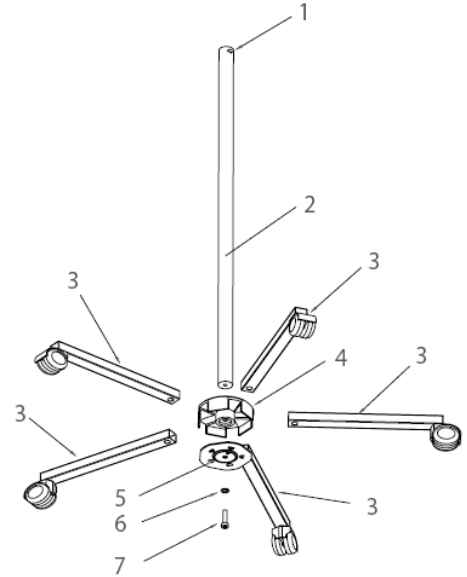

### 2.2 HM LIGHT Wall – Articulating Arm (HM28002W)

Wall Mount - 20W - Plug-in transformer

- A. Remove the screws in the wall plate (1&2).
- B. Remove the wall plate from casing (2)
- C. Drill 4 holes (8mm) in alignment with the holes in wall plate. Make sure plate is leveled. **NOTE! Wall plate must be mounted to wall stud or structural member.**
- D. Insert the anchors into the holes and attach the wall plate with the screws provided.
- E. Attach wall casing to the wall plate with provided screws.
- F. Make sure that the wall casing is securely fastened to the plate and adjust and tighten the arm as needed.
- G. Plug the transformer into power outlet and turn on lamp with switch on back of lamp head.

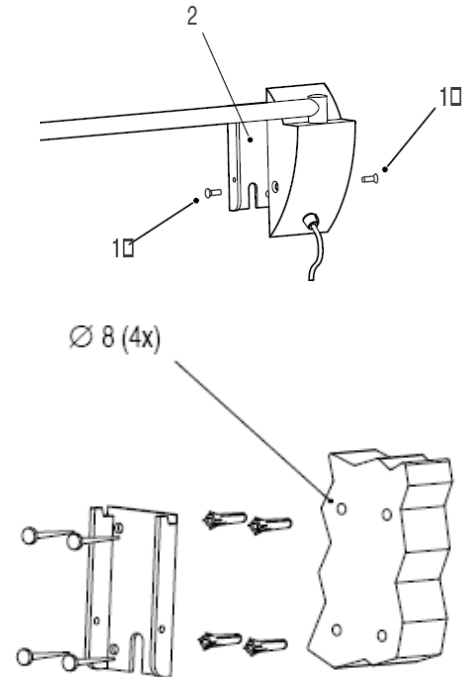

**CAUTION! The arm is equipped with friction joints. Do not tighten the joints excessively as this will cause uneven movement and could damage the arm.**

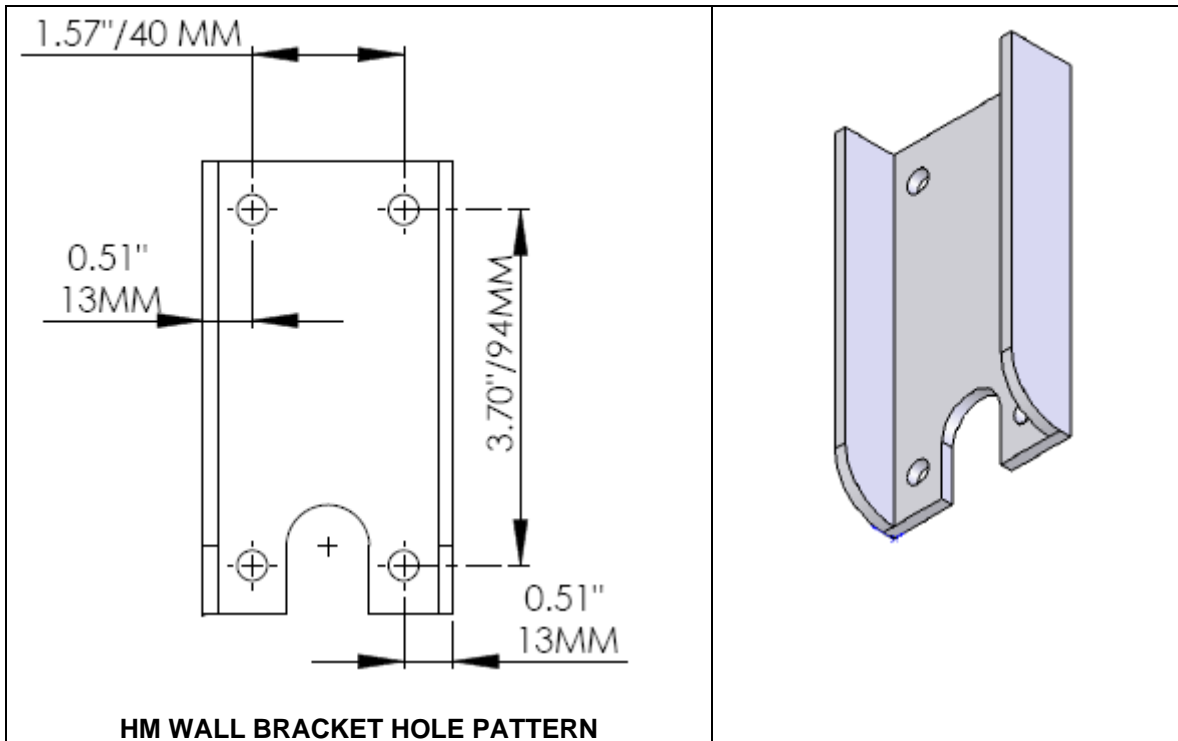

**2.3 HM LIGHT Wall - Gooseneck Arm (HM1000-37W)**

1. Mount the light using four screws. There are four holes on the universal mount.
2. Be sure transformer plug is not plugged into power source at this time.
3. After universal mount is secured, plug in the plug-in transformer to use the light.



**HM Light Wall – Gooseneck Arm**



**2.4 HM LIGHT Ceiling (HM2017-44)**

1. Securely fasten lamp down tube from ceiling. It is recommended that 6-5/16" diameter or larger fasteners of the proper length for your individual application be used. Be sure down tube is securely mounted to structural framework. Down tube should be mounted plumb and square to ceiling surface.

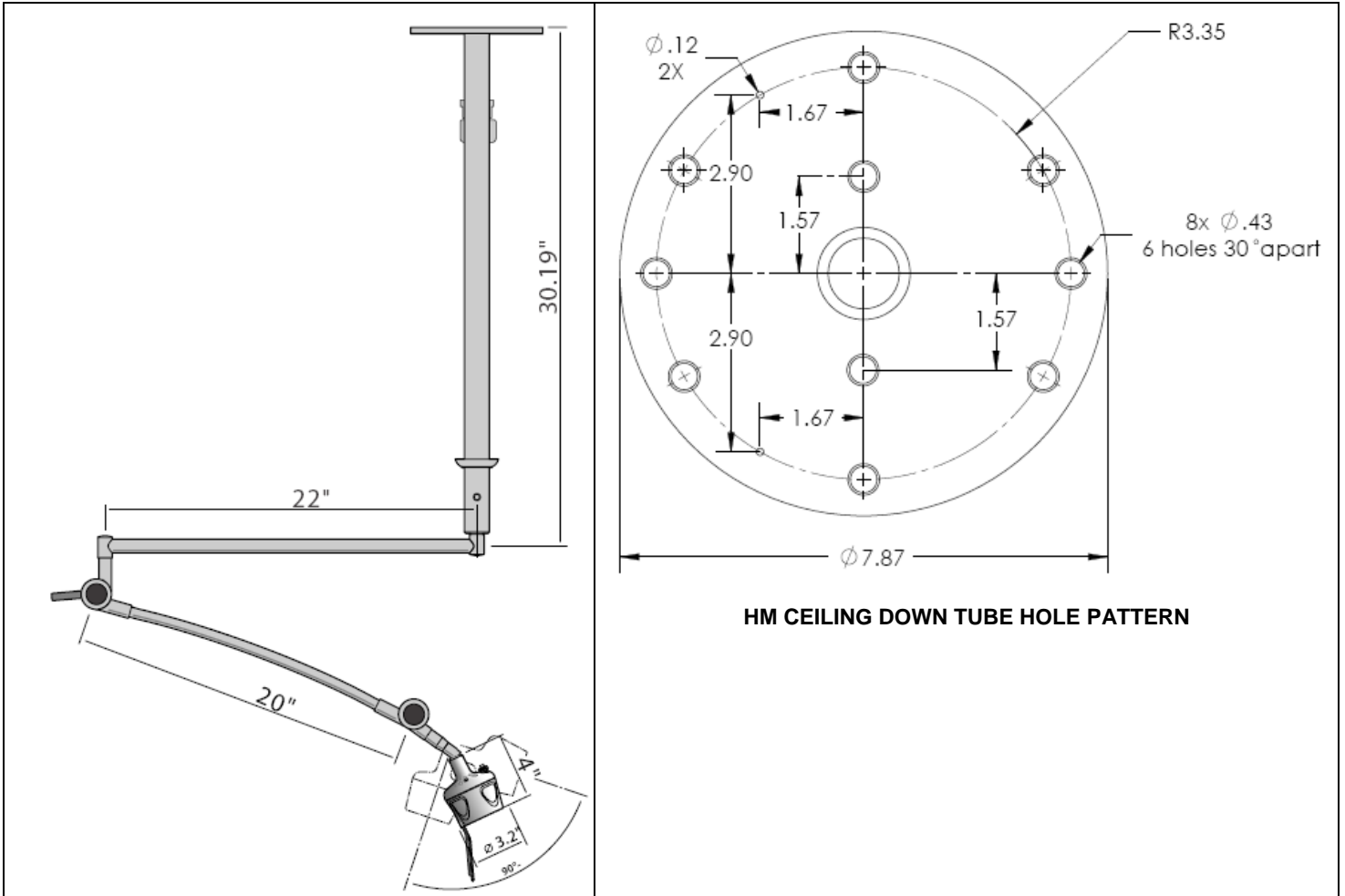
2. Be sure transformer plug is not plugged into power source at this time.
3. After down tube support is secured plug electrical connectors at the end of the down tube support and lamp arm together.



**2.6 Symbols**

CE-Mark	
AC powered:	
This product must be sorted as Waste from Electrical and Electronic Equipment (WEEE):	

**3. Sunnex Limited Warranty**

**3.1 Limited Warranty.**

Sunnex warrants that the Product, if properly used, will be free from defects in material and workmanship, for a period of three (3) years from the date of shipment to Customer. This Limited Warranty extends only to the original buyer. If the Product is determined to be defective within the

warranty period, Sunnex, at its option, will repair or replace the Product, at no charge or refund the then-current value of the Product.

### 3.2 Disclaimers and Limitations.

This Limited Warranty shall be the sole remedy of Customer and the sole liability of Sunnex to Customer.

This Limited Warranty does not extend or apply to any defects, failures or damage due to or resulting from: (a) acts of God, accident, misuse, use of the Product other than its normal and customary manner, abuse or negligence; (b) everyday wear and tear; (c) alteration or modification of, or to any part of, the Product; (d) improper operation and maintenance; or (d) any repairs or attempted repairs by anyone other than Sunnex. This Limited Warranty does not cover any products sold AS IS or WITH ALL FAULTS. This Limited Warranty excludes the replacement of bulbs for the Product.

TO THE FULL EXTENT PERMITTED BY APPLICABLE LAW, THIS LIMITED WARRANTY REPLACES ALL OTHER WARRANTIES OR CONDITIONS, EXPRESS OR IMPLIED INCLUDING, WITHOUT LIMITATION, ANY AND ALL IMPLIED WARRANTIES OF MERCHANTABILITY AND FITNESS FOR A PARTICULAR PURPOSE. SUNNEX DISCLAIMS ALL OTHER WARRANTIES AND CONDITIONS, EXPRESS OR IMPLIED, INCLUDING, WITHOUT LIMITATION, IMPLIED WARRANTIES OF TITLE, NONINFRINGEMENT, ABSENCE OF LIENS OR INCUMBRANCES, MERCHANTABILITY AND FITNESS FOR A PARTICULAR PURPOSE, REGARDLESS OF WHETHER SUNNEX KNOWS OR HAS REASON TO KNOW OF CUSTOMER'S PARTICULAR NEEDS. IF IMPLIED WARRANTIES MAY NOT BE DISCLAIMED UNDER APPLICABLE LAW, THEN ANY IMPLIED WARRANTIES THAT MAY BE IMPOSED BY LAW ARE LIMITED IN DURATION TO THE LIMITED WARRANTY PERIOD SET FORTH HEREIN, AND THEREAFTER ANY IMPLIED WARRANTIES ARE EXPRESSLY DISCLAIMED.

No employee, agent, dealer, reseller or distributor of Sunnex is authorized to modify this Limited Warranty, or to make any additional warranties.

REPAIR, REPLACEMENT OR REFUND, AS PROVIDED UNDER THIS LIMITED WARRANTY, ARE CUSTOMER'S SOLE AND EXCLUSIVE REMEDIES. IN NO EVENT SHALL SUNNEX BE LIABLE FOR ANY DIRECT, INDIRECT, SPECIAL, INCIDENTAL, CONSEQUENTIAL OR TORT DAMAGES OR LOSSES, WHETHER TO PERSON OR PROPERTY, INCLUDING DEATH, ARISING OUT OF OR RESULTING FROM ANY BREACH OF WARRANTY OR ANY OTHER LEGAL THEORY, OR ARISING OUT OF OR IN CONNECTION WITH THE PRODUCT OR CUSTOMER'S USE OF THE PRODUCT, EVEN IF SUNNEX IS ADVISED OF THE POSSIBILITY OF SUCH DAMAGES. IN ANY EVENT, THE TOTAL LIABILITY OF SUNNEX TO YOU FOR ANY CAUSE WHATSOEVER SHALL BE LIMITED TO THE PURCHASE PRICE YOU PAID FOR THE PRODUCT. THIS LIMITATION SHALL APPLY REGARDLESS OF THE FORM OF ACTION, WHETHER IN CONTRACT OR TORT (INCLUDING, WITHOUT LIMITATION, NEGLIGENCE).

SOME STATES DO NOT ALLOW THE EXCLUSION OR LIMITATION OF INCIDENTAL OR CONSEQUENTIAL DAMAGES, OR ALLOW LIMITATIONS ON HOW LONG AN IMPLIED WARRANTY LASTS, SO THE ABOVE LIMITATIONS OR EXCLUSIONS MAY NOT APPLY TO YOU. THIS LIMITED WARRANTY GIVES YOU SPECIFIC LEGAL RIGHTS, AND YOU MAY ALSO HAVE OTHER RIGHTS THAT VARY FROM STATE TO STATE.

### 3.3 Claims Procedure.

**(a)** Customer must contact Sunnex at (800)-445-7869 with a request for warranty service or to report a technical issue. Sunnex Technical Support will attempt to identify, diagnose and resolve the reported problem via the telephone.

**(b)** If attempts by Sunnex to resolve a reported problem are unsuccessful, Customer will then be provided with a Customer-specific Returned Merchandise Authorization number ("RMA"). The RMA number must be noted on any correspondence to Sunnex and displayed prominently on the outside

packaging of any Product shipped to Sunnex.

**(c)** Within ten (10) days of receipt of the RMA number, Customer must ship the Product to Sunnex at Customer's expense (insuring the Product is recommended) in either its original packaging or packaging affording an equal degree of protection, to *Sunnex Inc. 3 Huron Drive, Natick MA 01760*, with a statement describing the problem in reasonable specificity. Proof of purchase must be included to obtain warranty service. Sunnex will not be held responsible for shipping damages that occur in transit. Any damage to the Product during shipping will not be covered under this Limited Warranty and shall be subject to a service charge.

**(d)** Subject to the limitations specified herein, upon receipt, Sunnex will inspect the shipped Product and, at its sole discretion, repair or replace the Product with the same or a like product to the extent it does not conform to this Limited Warranty. In the event Sunnex, at its sole discretion, opts to replace the Product, should said product be discontinued or no longer be offered for sale by Sunnex, a like product in design and functionality will be provided to Customer.

**(e)** Sunnex will ship the repaired Product or a replacement to Customer within ten (10) business days after receipt from the date that Sunnex receives the Product. Standard shipments to the Customer will be paid by Sunnex. Sunnex assumes no responsibility for shipment delays by the carrier.

**(f)** If Customer requires warranty service to be provided in less than ten (10) business days, but not less than three (3) business days, Sunnex will charge Customer an additional One Hundred Dollars (\$100.00) express handling charge per request for each Product.

#### 3.4 Customer Responsibilities.

**(a)** To validated warranty customer is required to fill out online or provided warranty card.

**(b)** Customer is required to follow the user manual associated with the Product for proper operation.

**(c)** Customer is required to perform periodic preventive maintenance as called for in the user manual associated with the Product.

**(d)** Any modifications or repairs made to the Product without prior written authorization from Sunnex will render this Limited Warranty null and void. Instances whereby this is determined to be the case by Sunnex technical staff will be subject to an initial service charge of \$75.00 (\$25.00 evaluation charge and \$50.00 minimum labor cost).

#### 3.5 Miscellaneous.

In the event that any provision of this Limited Warranty should be or becomes invalid and/or unenforceable during the warranty period, the remaining provisions shall continue in full force and effect.

The provisions of this Limited Warranty shall be governed by the laws of the Commonwealth of Massachusetts without regard to its conflict of laws principles. This Limited Warranty shall not be modified except by an agreement signed by both parties specifically referencing this Limited Warranty.

This Limited Warranty represents the entire agreement between Sunnex and Customer with respect to the subject matter herein and supersedes all prior or contemporaneous oral or written communications, representations, understandings or agreements relating to this subject.

For service assistance or resolution of a service problem, or for Product or warranty information, write to *Sunnex Inc. 3 Huron Drive, Natick MA 01760*, or visit [www.sunnex.com](http://www.sunnex.com).

#### 3.6 Optional Extended Limited Warranty Plan.

The purchase of the Optional Extended Limited Warranty extends the duration of this Limited Warranty from a period of three (3) years to a period of five (5) years from the date of shipment to Customer. The Optional Limited Warranty may be purchased at the time of the original purchase of the Product or the Extended Limited Warranty to become effective and apply to the Product. Customer must pay the appropriate Extended Limited Warranty fee and upon initial purchase, register each Product with Sunnex within thirty (30) days from the date of shipment to Customer by Sunnex, or a Sunnex authorized dealer or reseller.



### Sunnex Customer Service

Sunnex Inc, USA	+ 1 508 651 0009
Sunnex Equipment AB Sweden	+ 46 565 177 00
Warranty	+ 1 508 651 0009

Guidance and manufacturer's declaration — electromagnetic emissions		
The HM LIGHT is intended for use in the electromagnetic environment specified below. The customer or the user of the HM LIGHT should assure that it is used in such an environment.		
Emissions test	Compliance	Electromagnetic environment — guidance
Emissions test CISPR 15	Complies	HM LIGHT may not be interconnected with other electrical equipment.
Harmonic emissions IEC 61000-3-2	Not applicable	The HM LIGHT is suitable for use in all establishments, including domestic establishments and those directly connected to the public low-voltage power supply network that supplies buildings used for domestic purposes.
Voltage fluctuations/ flicker emissions IEC 61000-3-3	Not applicable	

Guidance and manufacturer's declaration — electromagnetic immunity			
The HM LIGHT Image Intensifier is intended for use in the electromagnetic environment specified below. The customer or the user of the HM LIGHT Image Intensifier should assure that it is used in such an environment.			
Immunity test	IEC 60601 test level	Compliance level	Electromagnetic environment — guidance
Electrostatic discharge (ESD) IEC 61000-4.2	±6 kV contact ±8 kV air	±6 kV contact ±8 kV air	Floors should be wood, concrete or ceramic tile, If floors are covered with synthetic material, the relative humidity should be at least 30 %.
Electrical fast transient/burst IEC 61000-4-4	±2 kV for power supply lines	±2 kV for power supply lines	Mains power quality should be that of a typical commercial or hospital environment.
Surge IEC 61000-4-5	±1 kV differential mode  ±2 kV common mode	±1 kV differential mode  ±2 kV common mode	
Voltage dips, short Interruptions and voltage variations on power supply Input lines IEC 61000-4-11	<5 % $U_T$ (>95 % dip in $U_T$ ) for 0,5 cycle  40 % $U_T$ (60 % dip in $U_T$ )	<5 % $U_T$ (>95 % dip in $U_T$ ) for 0.5 cycle  40 % $U_T$ (60 % dip in $U_T$ )	Mains power quality should be that of a typical commercial or hospital environment, If the user of the HM LIGHT Image Intensifier requires continued operation during power mains Interruptions, It is recommended that the

	<p>for 5 cycles</p> <p>70 % <math>U_T</math> (30 % dip In <math>U_T</math>) for 25 cycles</p> <p>&lt;5% <math>U_T</math> (&gt;95 % dip In <math>U_T</math>) for 5 s</p>	<p>for 5 cycles</p> <p>70 % <math>U_T</math> (30 % dip in <math>U_T</math>) for 25 cycles</p> <p>&lt;5% <math>U_T</math> (&gt;95 % dip in <math>U_T</math>) for 5 s</p>	<p>HM LIGHT Image Intensifier be powered from an uninterruptible power supply or a battery.</p>
<p>Power frequency (50/60 Hz) magnetic field IEC 6 1000-4-8</p>	<p>3 A/m</p>	<p>0,3 A/m</p>	<p>If Image distortion occurs, It may be necessary to position the HM LIGHT Image Intensifier further from sources of power frequency magnetic fields or to install magnetic shielding. The power frequency magnetic field should be measured In the intended installation location to assure that It is sufficiently low.</p>
<p>NOTE <math>U_T</math> is the a.c. mains voltage prior to application of the test level.</p>			

**Guidance and manufacturer's declaration — electromagnetic immunity**

The HM LIGHT is intended for use In the electromagnetic environment specified below. The customer or the user of the HM LIGHT should assure that it is used in such an environment.

<b>Immunity test</b>	<b>IEC 60601 test level</b>	<b>Compliance level</b>	<b>Electromagnetic environment — guidance</b>
----------------------	-----------------------------	-------------------------	---

<p>Conducted RF IEC 61000-4-6</p>	<p>3 Vrms 150 kHz to 80 MHz</p>	<p>3 V</p>	<p>Portable and mobile RF communications equipment should be used no closer to any part of the HM LIGHT, including cables, than the recommended applicable to the frequency of the transmitter.</p> <p><b>Recommended separation distance</b></p> <p><math>d = 1,2 \sqrt{P}</math></p> <p><math>d = 1,2 \sqrt{P}</math> 80 MHz to 800 MHz</p> <p><math>d = 2,3 \sqrt{P}</math> 800 MHz to 2,5 GHz</p> <p>where <math>P</math> is the maximum output power rating of the transmitter in watts (W) according to the transmitter manufacturer and <math>d</math> is the recommended separation distance in metres (m).</p> <p>Field strengths from fixed RF transmitters, as determined by an electromagnetic site survey,<sup>a</sup> should be less than the compliance level in each frequency range.<sup>b</sup></p> <p>Interference may occur in the vicinity of equipment marked with the following symbol:</p> 
<p>NOTE 1 At 80 MHz and 800 MHz, the higher frequency range applies.</p> <p>NOTE 2 These guidelines may not apply in all situations. Electromagnetic propagation is affected by absorption and reflection from structures, objects and people.</p>			
<p><sup>a</sup> Field strengths from fixed transmitters, such as base stations for radio (cellular/cordless) telephones and land mobile radios, amateur radio, AM and FM radio broadcast and TV broadcast cannot be predicted theoretically with accuracy. To assess the electromagnetic environment due to fixed RF transmitters, an electromagnetic site survey should be considered. If the measured field strength in the location in which the HM LIGHT is used exceeds the applicable RF compliance level above, the HM LIGHT should be observed to verify normal operation. If abnormal performance is observed, additional measures may be necessary, such as re-orienting or relocating the HM LIGHT. <sup>b</sup> Over the frequency range 150 kHz to 80 MHz, field strengths should be less than 3 V/m.</p>			

**Recommended separation distances between portable and mobile RF communications equipment and the HM LIGHT**

The HM LIGHT is intended for use in an electromagnetic environment in which radiated RF disturbances are controlled. The customer or the user of the HM LIGHT can help prevent electromagnetic interference by maintaining a minimum distance between portable and mobile RF communications equipment (transmitters) and the HM LIGHT as recommended below, according to the maximum output power of the communications

equipment.

Rated maximum output power of transmitter <i>w</i>	Separation distance according to frequency of transmitter <i>m</i>			
	150 kHz to 80 MHz outside ISM bands $d = 3,5 \sqrt{P}$	150 kHz to 80 MHz in ISM bands $d = 12 \sqrt{P}$	80 MHz to 800 MHz $d = 1,2 \sqrt{P}$	800 MHz to 2,5 GHz $d = 2,3 \sqrt{P}$
0,01	0,35	1,2	0,35	0,35
0,1	1,1	3,8	1,1	1,1
1	3,5	12	3,5	3,5
10	11	38	11	11
100	35	120	35	35

For transmitters rated at a maximum output power not listed above, the recommended separation distance *d* in metres (m) can be determined using the equation applicable to the frequency of the transmitter, where *P* is the maximum output power rating of the transmitter in watts (W) according to the transmitter manufacturer.

NOTE 1 At 80 MHz and 800 MHz, the separation distance for the higher frequency range applies.

NOTE 2 The ISM (industrial, scientific and medical) bands between 150 kHz and 80 MHz are 6,765 MHz to 6,795 MHz; 13,553 MHz to 13,567 MHz; 26,957 MHz to 27,283 MHz; and 40,66 MHz to 40,70 MHz.

NOTE 3 An additional factor of 10/3 is used In calculating the recommended separation distance for transmitters In the ISM frequency bands between 150 kHz and 80 MHz and In the frequency range 80 MHz to 2,5 GHz to decrease the likelihood that mobile/portable communications equipment could cause interference If it is inadvertently brought into patient areas.

NOTE 4 These guidelines may not apply in all situations. Electromagnetic propagation is affected by absorption and reflection from structures, objects and people.

**REV. 1  
JULY 2008**